

# Iowa Board of Educational Examiners



## BoEE Superintendent Update – Dec. 2018/Jan. 2019

### Sign up to receive these updates under “Announcements”

If you have other staff members, such as human resource directors, principals, or teachers that you would like to receive these monthly updates, they may sign up on our website under “[announcements](#)” (left side bullet). Licensed educators will also receive our quarterly newsletter if we have a valid email address on file.

## Pathways to Licensure

The Iowa Board of Educational Examiners has created a document that describes different [pathways to Iowa licensure](#), including alternative pathways and CTE authorizations. This may be helpful as you begin planning for next year. Please share with principals and HR directors as well.

## Conditional Licenses - Check on Coursework Progress

Many of your staff members may hold a conditional license while they complete the coursework required to fully add a new endorsement. Districts are often surprised in August when they find out that a staff member has not completed enough coursework to either add the endorsement or to continue with conditional licensure. The district is then faced with the challenge of having a late opening in a shortage area.

Many Iowa districts have implemented policies to require any educator on a conditional license to check in with a designated administrator each semester to provide evidence of coursework progress. This allows the district and the educator to have open communication about licensure expectations and timelines, and it alleviates unexpected issues.

**This is a great time to check in with your educators who hold conditional licensure to ensure sufficient coursework progress is being made.**

## Can Nurses Teach Health?

The BoEE has received some questions recently about whether or not school nurses can teach health.

- School nurses who hold a statement of professional recognition may not teach any classes.
- There are some teachers with a full teaching license with a nurse endorsement who may teach health.
- Nurses with a career and technical authorization may teach health occupations courses.

## Hiring December Graduates

School districts may have openings or substitute positions available now or starting next semester. December graduates may teach or substitute teach once their Iowa initial license has been issued. All program completion assessments (Praxis II or edTPA) must be taken and passed prior to receiving an initial license or a substitute license.

If the candidate has completed their BoEE background check, we will typically issue their license within 24-48 hours of receiving the licensure recommendation from their Iowa college. Licensure for new out-of-state graduates may be delayed as it is less likely that they have completed the required assessment requirements for Iowa.

Once the bachelor's degree is conferred, candidates may apply for the substitute *authorization* if they are waiting to pass their assessments. This can only be used for substitute teaching, and cannot be used to hold a "spot" for a teaching position. This cannot be used for long-term subbing, and substitutes cannot fill an open position.

## Application Processing Time

New applications can take 4-6 weeks to process, and renewals may take up to 4 weeks. The length in processing time is due to reduced BoEE staff and increased time needed to process background checks. There is no way to "expedite" the process, as we process applications in the order in which they are received.

- Plan accordingly and submit applications in a timely manner (allow at least 4 weeks).
- Make sure to only apply for the application you need, and that no additional "boxes" have been checked, as our fees are non-refundable.
- Make sure to click "submit application", which is a step after the payment step.
- If someone has waited until just before their expiration date to renew, they should first apply for an extension.



## Iowa Board of Educational Examiners

### Teachers needed: Pathways to Licensure

The Iowa Board of Educational Examiners recognizes the need for teachers to be prepared to serve all students in Iowa, while also acknowledging that working adults may have incredible talents and knowledge to offer, including veterans and those working in skilled trades. Many of these adults may wish to pursue an alternative or accelerated pathway.



#### Career and Technical Authorization

This is a highly successful alternative program that helps to fill career and technical shortage areas including but not limited to construction, drafting, welding, mechanics, military, electricity, culinary, agriculture, engineering, technology, and many more.

This route requires hours of experience rather than a college degree. 6000 experience hours (approximately three years) or 4000 experience hours (if the applicant also has a bachelor's degree) are required.

Applicants can begin teaching immediately, and short courses in basic pedagogy are then completed online.

A position offer is required in order to apply for the initial career and technical authorization.

No testing is required.





## Community College Instruction

No licensure is required for instructors teaching community college courses, even if the teacher is employed by the school district, as long as the course is offered for college credit.

High school students earn both HS and college credit through these concurrent enrollment/dual credit courses.

## Fast-Track Teacher Intern Program

Applicants with a bachelor's degree and content coursework completed for the area they wish to teach will want to consider this pathway.

General pedagogy coursework is completed during the first year of the program, and an internship is secured during the second year at full salary in lieu of student teaching.

This is a highly successful alternative route program for those who wish to teach middle school and high school core courses beyond CTE areas (typically in shortage areas), and it removes the financial barrier of student teaching, thus allowing candidates to seamlessly transition from their current employment to education.

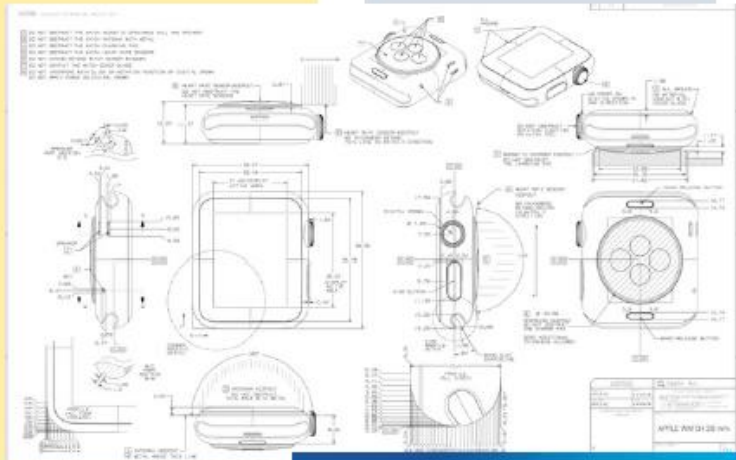

## Military Exchange License

This is a full teaching license for veterans and their spouses who have already completed a teacher preparation program in another state and wish to now teach in Iowa.

Most fees are waived, courses will not be listed as deficient, and no assessments are required during the three-year term of the license.



Photo Credit: Des Moines Public Schools Communications, Veteran's Day Celebration 2018

## Troops to Teachers

[Troops to Teachers](#) is a Department of Defense program designed to assist eligible military personnel in their pursuit of teaching as a second career in public schools where their skills, knowledge, and experience are most needed to relieve teacher shortages, especially in math, science, special education and other critical subject areas.

Troops to Teachers provides counseling, referral, and placement assistance to eligible military personnel. The TTT state and regional staff across the country will help applicants identify teacher certification requirements and programs leading to certification and employment opportunities in their state of interest.

Participants seeking Iowa licensure will complete one of the teacher pathways listed in the next section. Iowa has partnered with Missouri for the TTT program.

The TTT program coordinator is James Henley ([james.henley@dese.mo.gov](mailto:james.henley@dese.mo.gov)).





## Native Language Speaker Authorization

Applicants whose native language is one other than English may pursue this pathway to teach their native language. A bachelor's degree, language assessment (Praxis II), and a position offer are required. Applicants can begin teaching immediately, and short courses in basic pedagogy are then completed online.

## Traditional Pathway

This is usually a bachelor's or master's degree, and includes coursework in the content area to be taught, general pedagogy coursework, and a full student teaching placement.

Licensed applicants from another state will not be subject to the assessment requirements if they have at least three years of experience. Deficient coursework will be waived for applicants who have ten years of experience, or five years of experience and a master's degree.



**View Open Teaching Positions**

[www.teachiowa.gov](http://www.teachiowa.gov)

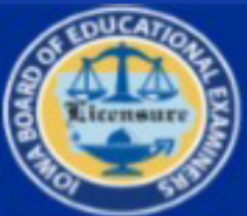

**Contact Us**

[www.boee.iowa.gov](http://www.boee.iowa.gov) or 515-281-3245